



12/6/2023  
 Quote #: 3100505R2  
 Sales Rep: SB  
 email: sam.bodell@comcast.net

TOOELE COUNTY CORPORATION  
 CONTRACT # 23-12-01



Part 2 of 2  
 Page 4 of 8

Order # \_\_\_\_\_  
 Est. Ship Date: \_\_\_\_\_  
 Draftsman: \_\_\_\_\_

### Building Purchase Order

**1. BUYER:** (where drawings will be mailed)

Name: Tooele County  
 Address: \_\_\_\_\_  
 City: \_\_\_\_\_  
 Contact: Aspen Wimmer  
 Phone: 435-843-3314  
 Cell: \_\_\_\_\_  
 Fax: \_\_\_\_\_  
 Email: aspen.wimmer@tooeleco.org

Project: Deseret Peak Complex 50x230

**2. OWNER:** (as it will appear on drawings)

Name: Deseret Peak Complex  
 Address: 2930 UT-112  
 City: Grantsville State: UT Zip: 84029  
 Contact: Aspen Wimmer  
 Phone: 435-843-3314

PROJECT ADDRESS  
 SAME

DELIVERY ADDRESS  
 (If different than project address)

Engineered Structural Steel Drawings For Construction: 3ea  
**NO PRODUCTION HOLD, NO SUBMITTALS REQUIRED**

**3. BUILDING DESIGN:**

Building Profile: Single Slope  
 Main Frame Type: tapered depth 7 beam column frames, clear span (Column elevation at 103'-0")  
 Width: 24'-0"  
 Length: 111'-4"  
 Height: 15'-6" Front Side Wall  
 11'-6" Back Side Wall  
 Inside Clearance: N A  
 Roof Slope: 2.0:12  
 Side Wall Bay Spacing: 2 at 18, 2 at 19.66, 2 at 18  
 Left End Wall: Non-expandable Rigid  
 Right End Wall: Non-expandable Rigid

Girt Design FSW / BSW Flush  
 Girt Design LEW: Flush  
 Girt Design REW: Flush

**4. LOADING CONDITIONS:**

Please Verify with your local building official the following information. Price is subject to change accordingly.

Building Use: Canopy  
 Building Code: IBC 2021 Risk Category II (Table 1604.5)  
 Live Load: 20 psf  
 Ground Snow Load: 27 psf  
 Roof Snow Load: 23.0 psf (Includes Thermal Ct=1.2, Exposure, Ce=1, Importance I=1)  
 Minimum Roof Snow Load: N A psf  
 Auxillary: 0 psf  
 Wind Load (Ultimate): 103 mph EXP: C Risk Category II  
 Seismic Site Class: D (Default) Seismic Acceleration Ss: 66.2% (I=1)  
 Crane Type: N A



Quote #: 3100505R2  
 Sales Rep: SB



Part 1 of 2  
 Page 3 of 8

- 12. LINER COVERING: NONE
- 13. PARTITIONS: NONE
- 14. SIDEWALL CANOPY: NONE
- 15. ENDWALL PURLIN EXTENSIONS: NONE

**16. ADDITIONAL INFORMATION:**

\*Mezzanine by others to be independent and self supporting  
 \* Includes 2 "CO Standard" Double Man Door Canopies 10'-4" W x 4' L with clear hight of 9' (See Sketch)

**PRICE & WEIGHT SUMMARY**

Price Includes parts 1, & 2

NET WITHOUT FREIGHT OR TAX:	\$	259,344.00	
FREIGHT: (Est. mileage: 150 )		<b>INCLUDED</b>	
SALES TAX: (6.75%)	\$	17,505.72	
TOTAL COST:	\$	276,849.72	
25% DEPOSIT	\$	69,212.43	
BALANCE DUE ON DELIVERY-COD	\$	207,637.29	
ESTIMATED WEIGHT: 86,020 lbs			

(To end of pavement only)

CERTIFIED FUNDS ONLY  
 PAYMENT REQUIRED WITH FIRST LOAD

\_\_\_\_\_  
 Craig D. Oberg, President      SELLER DATE: \_\_\_\_\_

I have reviewed items 1-16 and have determined all to be correct

Accepted by *[Signature]* BUYER DATE: \_\_\_\_\_

Purchase is subject to CO Building Systems Standard Terms and Conditions.

APPROVED AS TO FORM:

*[Signature]*  
 Nathan Harris  
 Deputy Tooele County Attorney



Quote #: 3100505R2  
 Sales Rep: SB



Part 1 of 2  
 Page 2 of 8

**5. ROOF COVERING**

Roof Color:	Hunter Green	Trim Color:	
Roof Panel Type:	MBCI BATTENLOK HS (seamer rental	Trim Type:	Commercial
Roof Gauge:	24 by others)		
Clip:	1/2" Offset / Floating	Purlin Bridging:	By SNS
Roof Lights:	NONE		

**6. WALL COVERING**

Wall Color:	Light Stone	Trim Color:	
Wall Panel Type:	6.8		
Wall Gauge:	26		
Fastener Length:	BY SNS		
Base Support:	Die Formed Base		
Wall Lights:	NONE		

**7. DOOR FRAMED OPENINGS**

Front Sidewall:	(2) 12 W x 12 H
	(4) 14 W x 14 H
	(2) 16 W x 16 H
Back Sidewall:	(2) 14 W x 14 H
	(2) 16 W x 16 H
Left Endwall:	none
Right Endwall:	none
Door Jamb Cover Color:	

**8. GUTTERS & DOWNSPOUTS**

(Not recommended over 1:12 roof pitch or greater)

Front Sidewall:	230 Inft	Front Sidewall Downs:	4
Back Sidewall:	230 Inft	Back Sidewall Downs:	4
Gutter Color:		Down Spout Color:	

**9. WALK DOORS**

Quantity:	5 - 3070M	Walk Door with lever lockset
	5 - 3070M	Walk Door with Panic Hardware and Closers

**10. WINDOW FRAMED OPENINGS**

Quantity:	8 6040 WINDOW F.O. - (8" CEE)	Sill at 3'
-----------	-------------------------------	------------

**11. INSULATION**

Roof Insulation :	SNS Full Cavity with banding	Wall Insulation:	8 "
Roof Facing:	WMPVR (Tabs Over the purlin)	Wall Facing:	Energy Craft Hangers & Thermal Tape



12/6/2023  
 Quote #: 3100505R2  
 Sales Rep: SB  
 email: sam.bodell@comcast.net



Part 1 of 2  
 Page 1 of 8

Order # \_\_\_\_\_  
 Est. Ship Date: \_\_\_\_\_  
 Draftsman : \_\_\_\_\_

### Building Purchase Order

#### 1. BUYER: (where drawings will be mailed)

Name: Tooele County Project: Deseret Peak Complex 50x230  
 Address: \_\_\_\_\_  
 City: \_\_\_\_\_  
 Contact: Aspen Wimmer  
 Phone: 435-843-3314  
 Cell: \_\_\_\_\_  
 Fax: \_\_\_\_\_  
 Email: aspen.wimmer@tooeleco.org

#### 2. OWNER: (as it will appear on drawings)

Name: Deseret Peak Complex PROJECT ADDRESS  
 Address: 2930 UT-112 SAME  
 City: Grantsville State: UT Zip: 84029  
 Contact: Aspen Wimmer DELIVERY ADDRESS  
 Phone: 435-843-3314 (If different than project address)

Engineered Structural Steel Drawings For Construction: 3ea  
**NO PRODUCTION HOLD, NO SUBMITTALS REQUIRED**

#### 3. BUILDING DESIGN:

Building Profile: Symmetrical Double Slope  
 Main Frame Type: 'tapered depth 11 rigid frames, clear span  
 Width: 50'-0" 2 rigid frames, with interior column at CO option, LEW&REW  
 Length: 230'-0"  
 Height: 19'-0" Front Side Wall  
 19'-0" Back Side Wall  
 (3' stem wall + 16' sheeting = 19' total eave height)  
 (Main frame columns to the floor, End Wall Columns top of wall, door jambs top of wall)  
 Inside Clearance: N A  
 Roof Slope: 2.0:12  
 Side Wall Bay Spacing: 1 at 19, 1 at 22.33, 3 at 18, 2 at 19.66 Girt Design FSW / BSW Bypass  
 3 at 18, 1 at 22.33, 1 at 19  
 Left End Wall: Expandable Rigid (19' Bay) Girt Design LEW: Flush  
 Right End Wall: Expandable Rigid (19' Bay) Girt Design REW: Flush

#### 4. LOADING CONDITIONS:

Please Verify with your local building official the following information. Price is subject to change accordingly.

Building Use: \_\_\_\_\_  
 Building Code: IBC 2021 Risk Category II (Table 1604.5)  
 Live Load: 20 psf  
 Ground Snow Load Pg 27.0 psf  
 Flat Roof Snow Load Pf: 20.0 psf (Includes Thermal Ct=1, Exposure, Ce=1, Importance I=1)  
 Minimum Roof Snow Load : N A psf  
 Auxiliary: 5 psf  
 Wind Load (Ultimate): 103 mph EXP: C Risk Category II  
 Seismic Site Class: D (Default) Seismic Acceleration Ss: 66.2% (I=1)  
 Crane Type: N A



Quote #: 3100505R2  
Sales Rep: SB



Part 2 of 2  
Page 5 of 8

**5. ROOF COVERING:**

Roof Color:	Hunter Green	Trim Color:	
Roof Panel Type:	MBCI BATTENLOK HS (seamer rental	Trim Type:	Commercial
Roof Gauge:	24		
Fastener Length:	1/2" Offset / Floating		

1 x 1 angle X pattern between purlins

**6. WALL COVERING: Roof Only**

NO X Bracing in the Side Walls. Weak Axis Bracing

- 7. DOOR FRAMED OPENINGS: NONE
- 8. GUTTERS & DOWNSPOUTS: NONE
- 9. WALK DOORS: NONE
- 10. WINDOW FRAMED OPENINGS: NONE
- 11. INSULATION: NONE
- 12. LINER COVERING: NONE
- 13. PARTITIONS: NONE
- 14. SIDEWALL EAVE EXTENSIONS: NONE
- 15. ENDWALL PURLIN EXTENSIONS: NONE

**16. ADDITIONAL INFORMATION:**

**PRICE & WEIGHT SUMMARY**

Price is Included with part 1 of 2

ESTIMATED WEIGHT: See Part 1 of 2

SELLER DATE: \_\_\_\_\_  
Craig D. Oberg, President

I have reviewed items 1 - 16 and have determined all to be correct

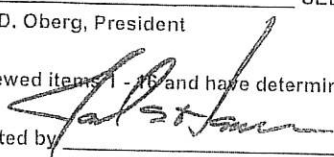
Accepted by:  BUYER DATE: \_\_\_\_\_

Purchase is subject to CO Building Systems Standard Terms and Conditions.

APPROVED AS TO FORM:



90 of 133 Nathan Harris  
Deputy Tooele County Attorney



12/6/2023  
 Quote #: 3100505R2  
 Sales Rep: SB  
 email: sam.bodell@cobuildings.net



Order # \_\_\_\_\_  
 Est. Ship Date: \_\_\_\_\_  
 Draftsman : \_\_\_\_\_

**Project Design Information**

Dear Building Official:  
 In order to comply with Your Local Building Codes, we have collected the following data for a project under your jurisdiction. Please review this information for accuracy.

Local Building Official: \_\_\_\_\_  
 City/County: \_\_\_\_\_  
 Phone: \_\_\_\_\_  
 Email: \_\_\_\_\_

(RDPRC) Registered Design Professional In Responsible Charge, See IBC Section 202 (NOT CO Building Systems)

Name: \_\_\_\_\_  
 Phone: \_\_\_\_\_  
 Email: \_\_\_\_\_

Project Name: Deseret Peak Complex  
 Project Address: 2930 UT-112  
 City: Grantsville County: Tooele State: UT Zip Code: 84029  
 Elevation: \_\_\_\_\_

Building Use: \_\_\_\_\_

Required Code For Design:	IBC 2021	Risk Category II (Table 1604.5)	
Live Load:	20	psf	
Ground Snow Load:	27.0	psf	
Part 1 Roof Snow Load:	20.0	psf (Includes Thermal Ct=1, Exposure, Ce=1, Importance I=1)	
Part 2 Roof Snow Load:	23.0	psf (Includes Thermal Ct=1.2, Exposure, Ce=1, Importance I=1)	
Min Roof Snow Load Pm:	N A	psf	
Auxiliary:	5	psf	
Wind Load (Ultimate):	103 mph	EXP: C	Risk Category II
Seismic Site Class:	D (Default)	(I=1)	
Seismic Acceleration Ss:	66.2%	Seismic Acceleration S1:	23.8%
Fa:	1.27	Fv:	2.13
Ss x Fa = Sms:	0.84	S1 x Fv = Sm1:	0.51

Thermal Block Required: NO  
 Roof Insulation Required: \_\_\_\_\_  
 Wall Insulation Required: \_\_\_\_\_

If your requirements differ from the above, please make corrections on this letter and send back to us within 24 hours. We cannot begin Engineering or Design until we have this document returned to our office with a signature below.

Thank you for your efforts,  
 CO Building Systems, Inc.

Signed: \_\_\_\_\_ Date: \_\_\_\_\_

Bldg Official Buyer Owner RDPRC (Circle One)

Price Quotes are subject to change thirty (30) days after issue date of Original Quote Confirmation. Any item not specifically stated as included on the document is excluded. Standard C O BUILDINGS specifications are assumed unless specifically amended on this document. Attached documents do not fulfill this requirement. Signature of buyer indicates that he/she understands that 25% Deposit is required upon return of this document to C O BUILDING SYSTEMS and all remaining balances are due upon receipt of said building unless other arrangements are made prior to shipment. Buyer agrees that regardless of his or her circumstances, or other arrangements, payment will be made in full on or before the end of the month in which the said building was received. All overdue accounts will be charged interest at the rate of 1.5% or 18% per annum. Purchaser also agrees that in the event of legal action, he/she is responsible for all expenses incurred By Seller.

## CONDITIONS

1. Shipments and deliveries shall be subject to approval of Seller. If Purchaser fails to fulfill the terms of payment, Seller may defer further shipments or may, at its option, cancel the unshipped balance of this order and all other of Purchaser's then unfilled orders. Seller reserves the right, previous to making any shipments, to require from Purchaser satisfactory security for performance of Purchaser's obligations. Seller also reserves the right to divide this order into separate shipments and invoice such shipments separately, in which case each shipment shall be deemed a separate contract and payment therefore due in accordance with the terms hereof. If, because of default of Purchaser, any shipment must be diverted or returned to Seller, Purchaser shall pay all demurrage, transportation and other costs incurred as a result thereof. No failure of Seller to exercise any rights accruing from any default of Purchaser shall impair Seller's rights in case of any subsequent default of Purchaser. All rights of Seller hereunder shall be cumulative.
  2. The seller shall not be liable or responsible for loss, damage, or delays in deliveries due to fires, strikes, lockouts or other labor troubles, floods, car shortage, embargoes, transportation delays, accidents at Mill, Government Regulations, Including Preference, Allocation or Priority systems for Government and other orders, or other contingencies beyond Seller's control, nor liable for consequential damages from any cause whatsoever.
  3. Any taxes which the Seller may be required to pay or collect, under existing or future law, upon or with respect to the sale, purchase, delivery, storage, processing, use, consumption or transportation of any of the materials covered hereby, shall be for the account of the Purchaser, who shall promptly pay the amount thereof to the Seller upon demand.
  4. Claims for errors, shortages, imperfections, deficiencies, etc., will not be entertained by Seller unless made within seven (7) days after receipt of goods and Seller shall not in any event be liable for labor charges or consequential damages arising from the use of defective material. In no event shall Seller's liability exceed the purchase price of the material. In case any material furnished by Seller is not in accordance with this order it is understood that the Purchaser will immediately discontinue its use and advise the Seller of the facts in order that the Seller may have the opportunity of deciding what shall be done in the circumstances so that possible loss or damage to either party shall be prevented or minimized.
  5. Materials shall be within the limits and of the sizes published by the Seller, and subject to permissible variations in accordance with the Seller's or Manufacturers' Standard practice.
  6. Seller shall not be responsible for loss of, or damage to goods in transit.
  7. Where Purchaser is to inspect, inspection and acceptance must be made before shipment.
  8. Orders that are cancelled by the Purchaser are subject to cancellation charges determined by the Seller. All orders, unless otherwise agreed upon in writing, are for unrestricted shipment at Seller's convenience. It is distinctly understood that the Purchaser will not issue instructions to delay manufacture for shipment of the material. Seller may invoice Purchaser for work completed to date on orders that are placed on hold by the Purchaser, and Purchaser agrees to pay for such work completed within thirty (30) days. When manufactured material has to be stored, storage charges determined by the Seller will be charged.
  9. Seller's acceptance or shipment of Purchaser's order shall not imply the renewal, extension, or creation of any agreement between Purchaser and Seller not in effect at this date.
  10. Seller warrants only that its products are free from defects in materials and workmanship on the date of shipment from its plant. Seller's obligation under this warranty shall be limited to repairing or replacing (but not dismantling and installing) such products which prove to be thus defective within one (1) year from date of the original shipment by Seller and which Seller's examination shall disclose to be thus defective. Any products so repaired or replaced as provided herein shall be subject to warranty only for the remainder of the time applicable to the original warranty period.  
 Seller assumes no responsibility for buildings which are loaded beyond the design for live and wind loads by unusual conditions such as crane loads and bulk storage loads, or for buildings subjected to misuse, neglect, improper erection, abnormal weather conditions, acts of God, or inadequate foundations.  
 Seller shall determine whether correction of any defect or failure under this warranty shall be by repair or replacement. Seller's liability shall not arise unless repairs are made under the supervision of or with written approval of Seller. Shipping costs incurred in returning defective material shall be paid by Seller, but only if Seller authorizes such shipment in writing. If Seller's examination proves the product to be defective as herein defined, return shipment shall be prepaid by Seller, otherwise, return shipment shall be freight collect to the consignee. Title to any replaced material shall pass to Seller. This warranty does not cover products, accessories, parts or attachments, such as hinged doors and hardware, aluminum sliding sash, ventilators, and sectional overhead doors, which are not manufactured by Seller, except to the extent of the warranty given Seller by the actual manufacturer. All claims filed under the provisions of this warranty must be presented to Seller in writing, delivered by Registered or Certified mail, during the warranty period and not more than thirty (30) days after detection of any apparent defects.  
 This warranty is extended to the original owner of the products purchased hereunder and is not transferable and non-assignable.
- THERE ARE NO OTHER WARRANTIES, EXPRESSED OR IMPLIED, WHICH EXTEND BEYOND THE DESCRIPTION ON THE FACE OF THIS AGREEMENT, INCLUDING ANY WARRANTIES OF MERCHANTABILITY OR FITNESS FOR A PARTICULAR PURPOSE, AND SELLER SHALL NOT BE RESPONSIBLE FOR ANY INDIRECT OR CONSEQUENTIAL DAMAGES (SUCH AS DAMAGES TO THE CONTENTS OR FURNISHINGS OF ANY BUILDING) OR ANY LOSS OF ANY KIND WHATSOEVER.
11. Unless otherwise indicated, all shipments are F. O. B. Seller's Plant. Freight and/or hauling charges are for the account of the purchaser. Standard Freight if included is over Paved Roads only. Improved Gravel Roads require double the rate per mile, (28 feet min width gravel surface) Freight over unimproved roads is not allowed. Freight beyond improved roads is at jobsite only. Driver's discretion will govern.
  12. Should payment not be received within the time specified or agreed to, interest at the rate of 1 1/2 % per month (18% APR) or the maximum allowed by state law will be added. In case suit is instituted to collect any portion of monies payable under this contract or to enforce or defend any of its terms and conditions, the Purchaser agrees to pay such additional sum as the court may adjudge reasonable as Seller's attorney's fees and court costs.

BACK SIDEWALL

QUOTE #3100505R2  
 Part 1 of 2  
 PAGE 7 OF 8  
 Date: 12/06/23

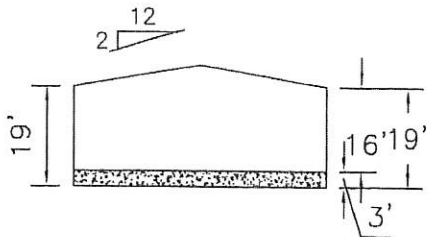
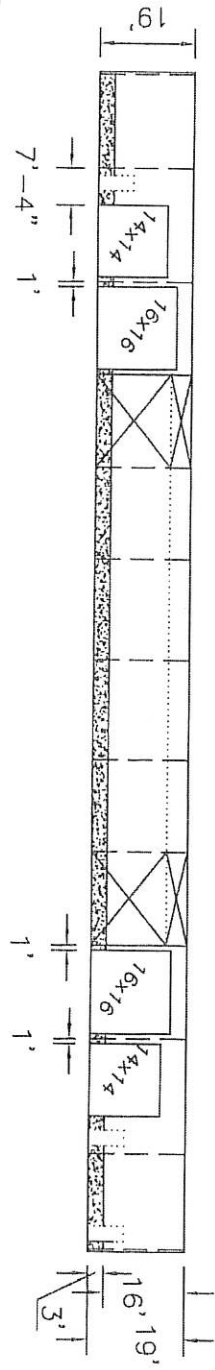

LEFT ENDWALL

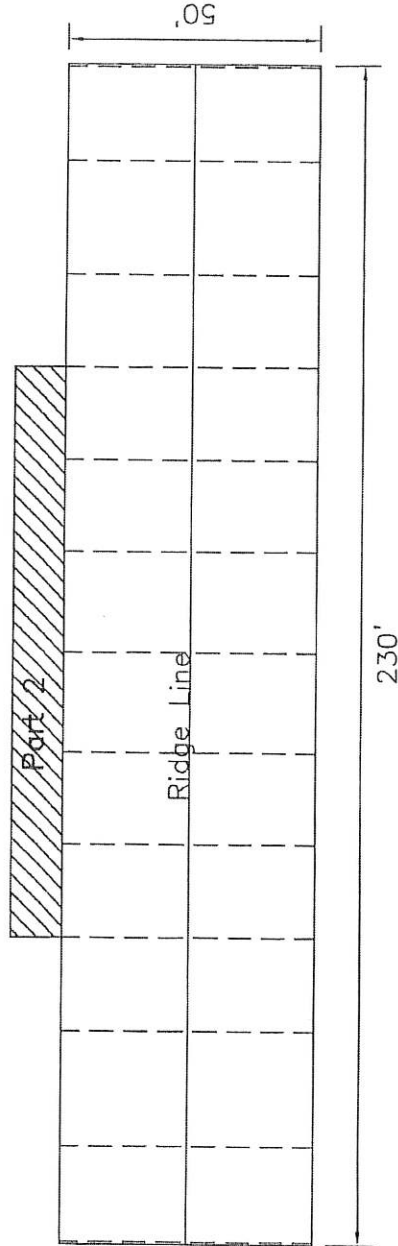

RIGHT ENDWALL

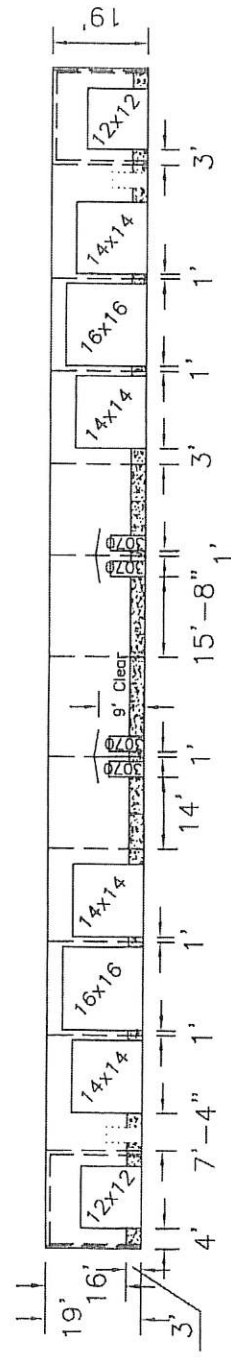
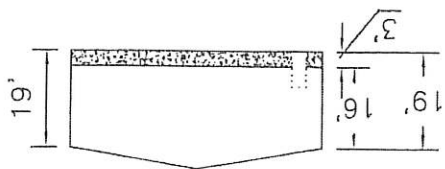

NOTES:



FRONT SIDEWALL



APPROVED  
DATE

BACK SIDEWALL

QUOTE #3100505BR2  
Part 2 of 2  
PAGE 8 OF 8  
Date: 12/06/23

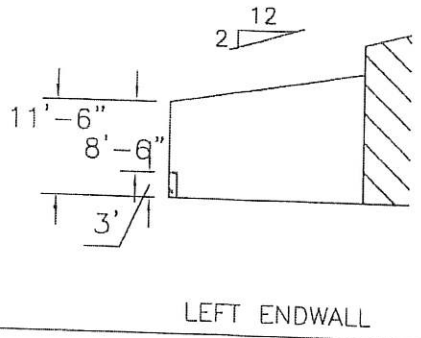
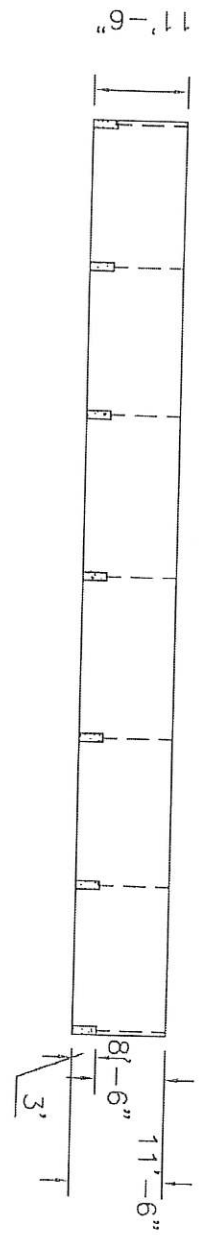

LEFT ENDWALL

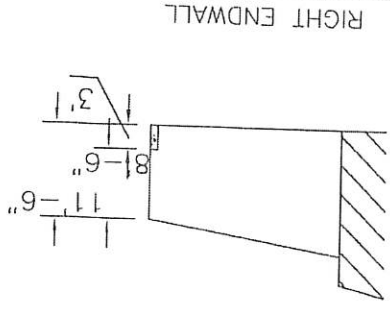

RIGHT ENDWALL

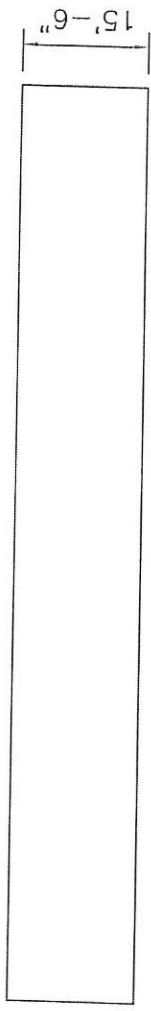
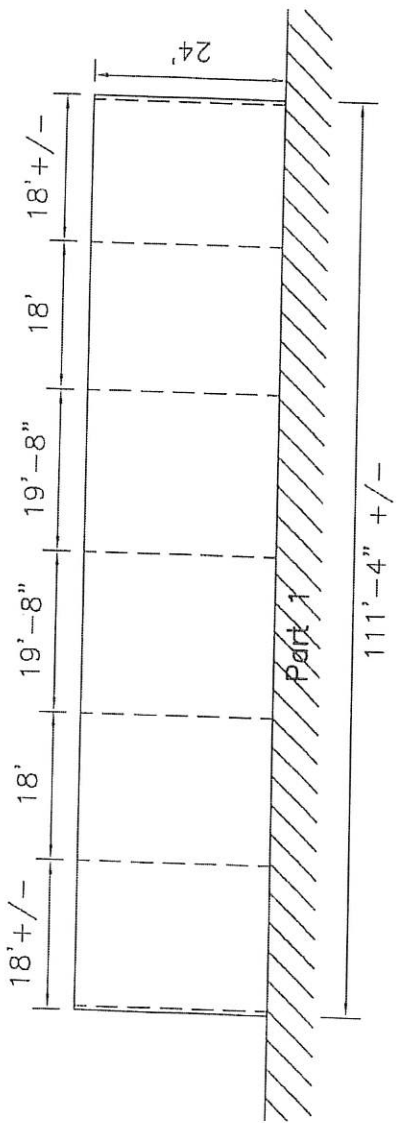

FRONT SIDEWALL

NOTES:

ROOF  
ONLY

